

REPAIR DETAIL C
(5 Req'd)

Fasteners shall be high strength bolts. Bolts $\frac{3}{4}$ " ϕ , open holes $\frac{13}{16}$ " ϕ , unless otherwise noted. New holes in existing members are to be filled drilled using holes in new members as a template.

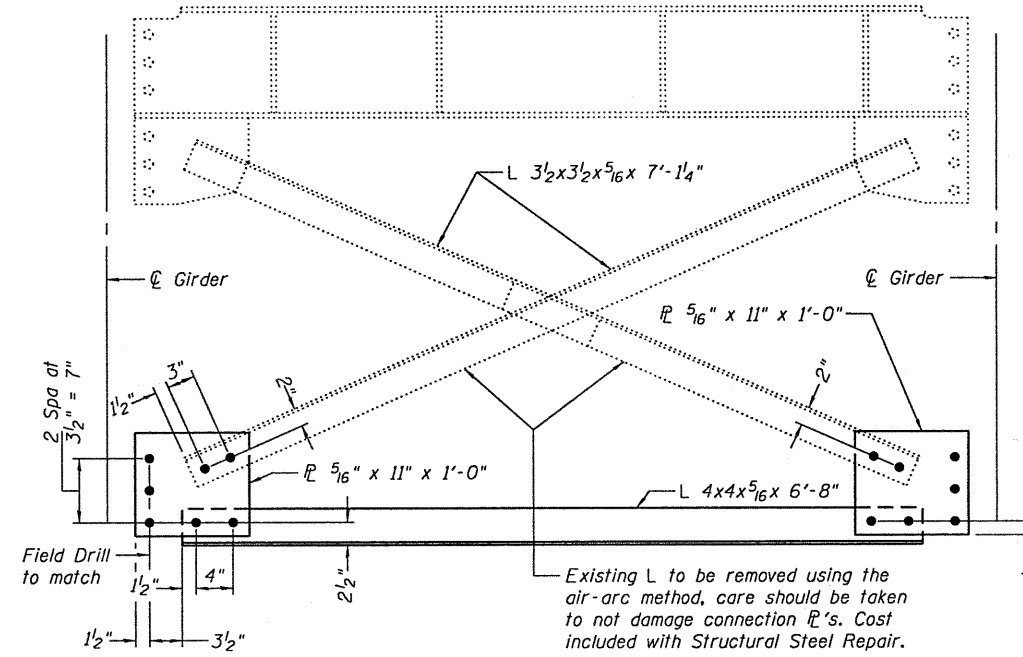

REPAIR DETAIL D
(2 Req'd)

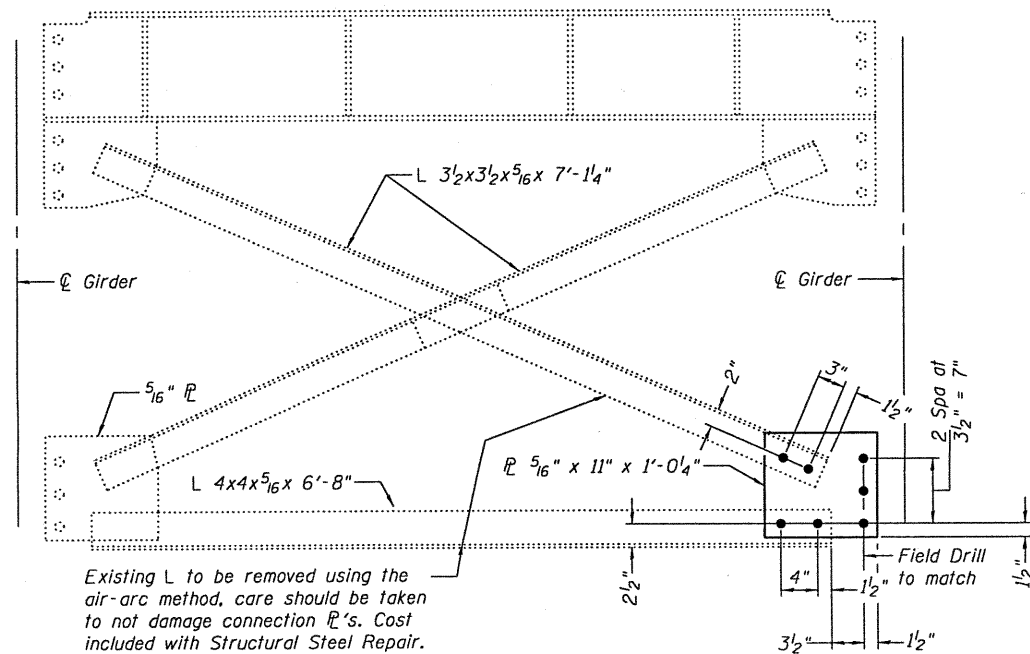

REPAIR DETAIL E
(1 Req'd)

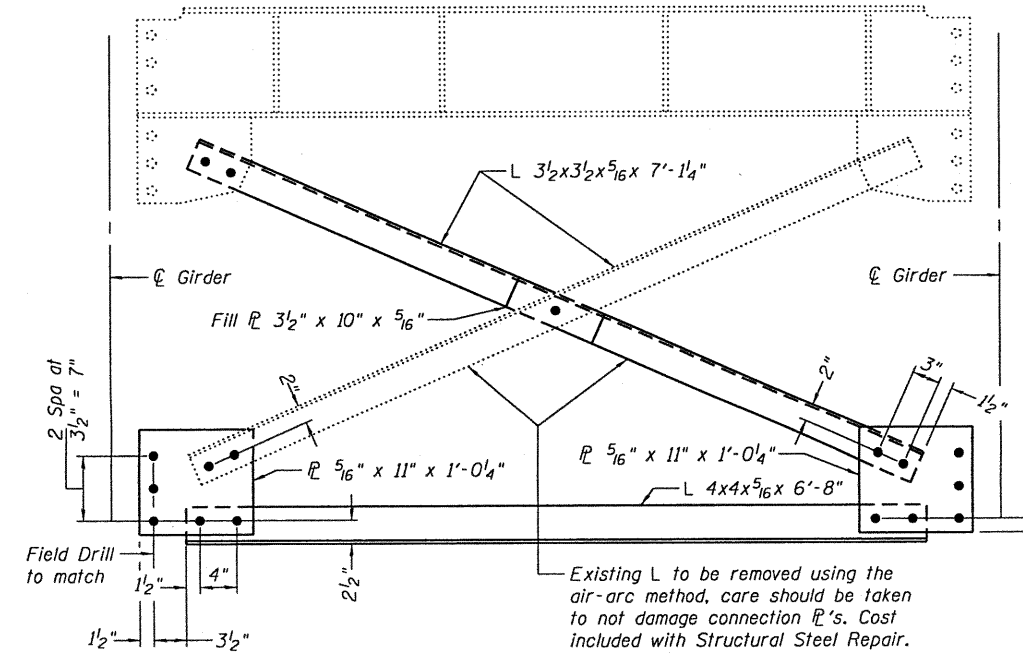

REPAIR DETAIL F
(1 Req'd)

DESIGNED - A.T.H.
CHECKED - M.K.C.
DRAWN - **Drew Christopher**
CHECKED - A.T.H. M.K.C.

EXAMINED *Carl Proyer* DATE - NOVEMBER 22, 2010
ENGINEER OF STRUCTURAL SERVICES
PASSED *Ralph E. Anderson*
ENGINEER OF BRIDGES AND STRUCTURES

STATE OF ILLINOIS
DEPARTMENT OF TRANSPORTATION

DETAILS
SN 060-0036 & 0037

F.A.I. RTE.	SECTION	COUNTY	TOTAL SHEETS	SHEET NO.
270	60-1B-1-4	Madison	9	8
CONTRACT NO. 76E58				
ILLINOIS FED. AID PROJECT				

SHEET NO. 5 OF 6 SHEETS

SLT-98-001-10