

EXISTING TYPICAL SECTION

STA. 93+81 TO 94+93

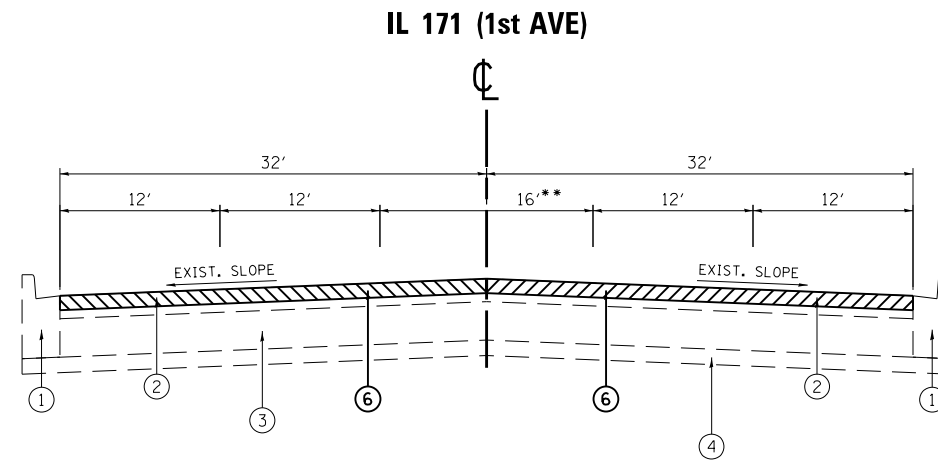

EXISTING TYPICAL SECTION

STA. 91+64.5 TO 93+81
STA. 94+93 TO 97+90

**VARIES BETWEEN PAINTED MEDIAN AND LEFT TURN LANE.
SEE PAVEMENT MARKING PLAN SHEETS FOR LOCATIONS.

LEGEND

- ① EXISTING COMBINATION CONCRETE CURB AND GUTTER, TYPE B-6.24
- ② EXISTING HMA SURFACE COURSE, VARIES 4"±
- ③ EXISTING PCC BASE COURSE, VARIES 10"±
- ④ EXISTING SUBBASE GRANULAR MATERIAL, 6"
- ⑤ EXISTING CONCRETE MEDIAN
- ⑥ PROPOSED HOT-MIX ASPHALT SURFACE REMOVAL - 2 1/2"
- ⑦ PROPOSED MEDIAN REMOVAL
- ⑧ PROPOSED POLYMERIZED HOT-MIX ASPHALT SURFACE COURSE, MIX "F", N90, 1 3/4"
- ⑨ PROPOSED POLYMERIZED LEVELING BINDER (MACHINE METHOD), IL 4.75, N50, 3/4"
- ⑩ PROPOSED HOT-MIX ASPHALT BASE COURSE, 9"
- ⑪ PROPOSED AGGREGATE SUBGRADE IMPROVEMENT, 12"
- ⑫ PROPOSED COMBINATION CONCRETE CURB AND GUTTER REMOVAL AND REPLACEMENT (LOCATIONS TO BE DETERMINED BY THE RESIDENT ENGINEER)

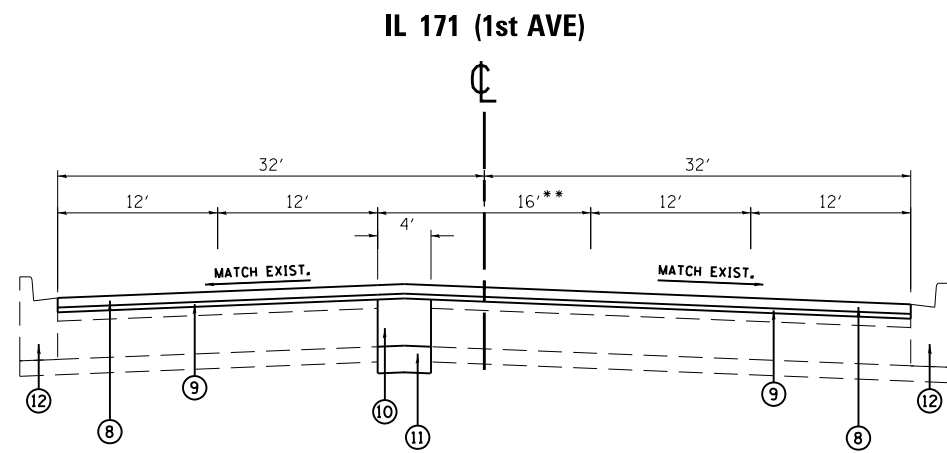

PROPOSED TYPICAL SECTION

STA. 93+81 TO 94+93

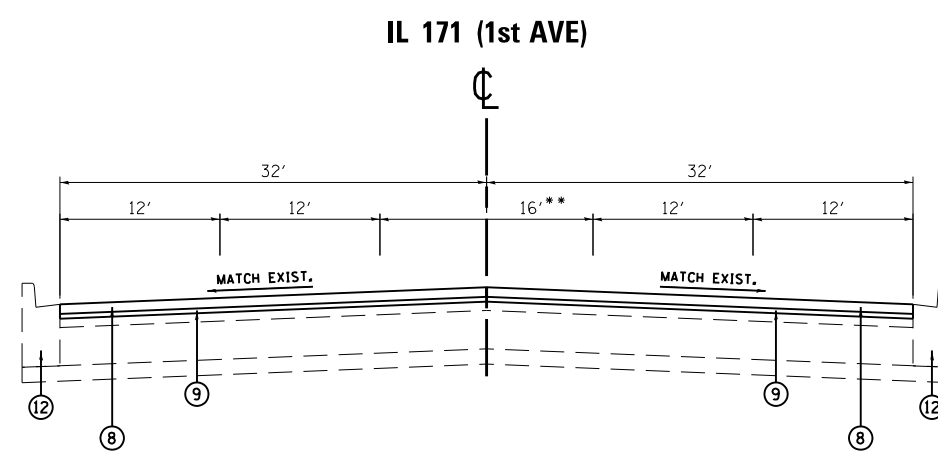

PROPOSED TYPICAL SECTION

STA. 91+64.5 TO 93+81
STA. 94+93 TO 97+90

FILE NAME =	USER NAME = plascencia	DESIGNED -	REVISED -	STATE OF ILLINOIS DEPARTMENT OF TRANSPORTATION	EXISTING AND PROPOSED TYPICAL SECTIONS IL RTE 171 (1ST AVE) & PLAINFIELD RD	F.A.P. RTE.	SECTION	COUNTY	TOTAL SHEETS	SHEET NO.	
et:\pw\work\p\id\plascencia\1\0316539\p	08212-sht-typical.dgn	DRAWN -	REVISED -			372	2012-0471	COOK	63	14	
Default	PLOT SCALE = 100.0000' / 1in.	CHECKED -	REVISED -			CONTRACT NO. 60V34					
	PLOT DATE = 10/18/2013	DATE -	REVISED -			SCALE:	SHEET	OF	SHEETS	STA.	TO

ILLINOIS FED. AID PROJECT